

Rev.	Description	Date
1	New Release	3/9/05

Standard Body Assembly

long and extra-long body assemblies are similar, just having an extra one or two battery mounting positions

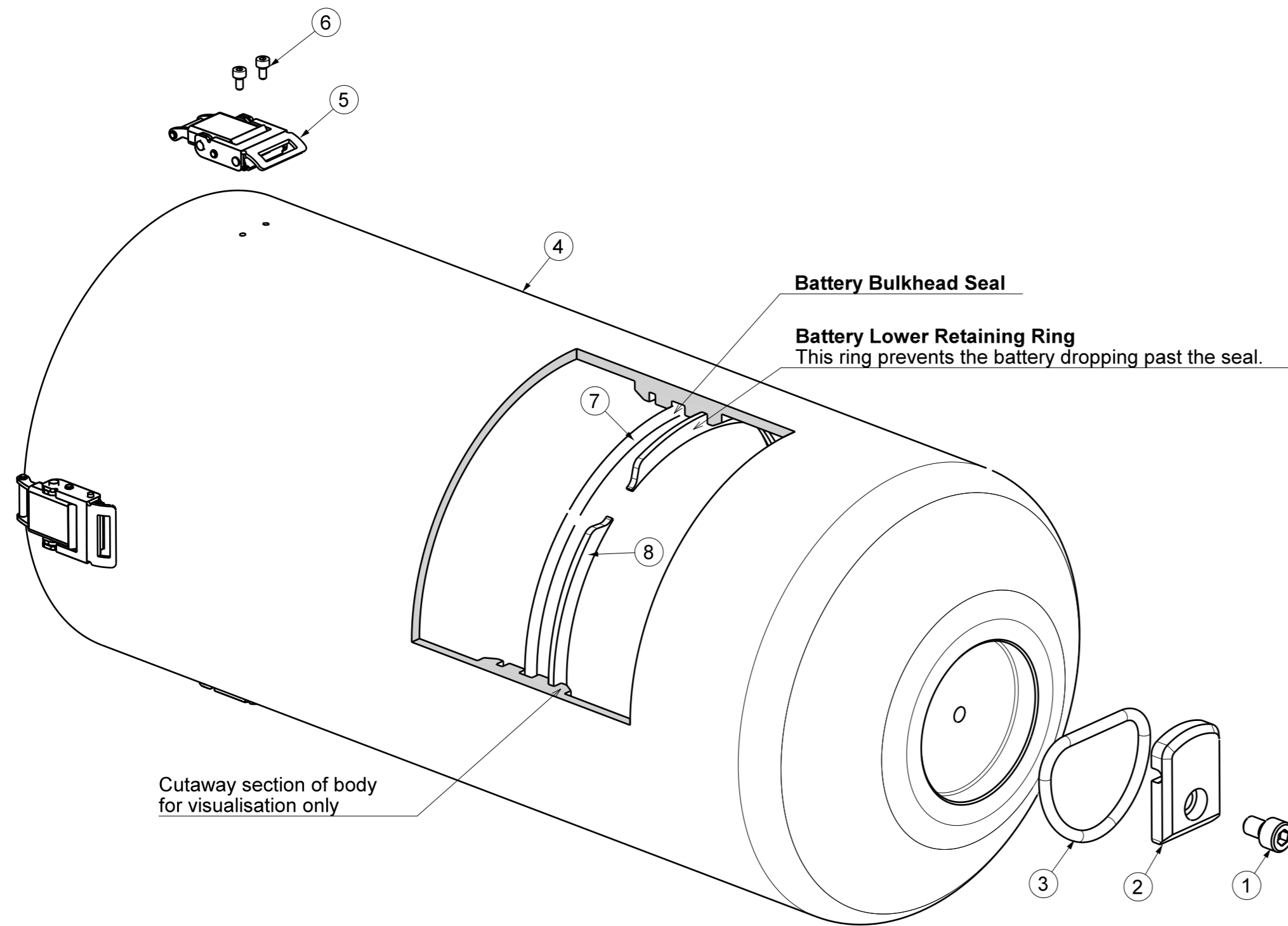

Electrical Circuit

The diagram below shows the electrical circuit. Replacement electronics come complete requiring only the connection of solder joint 2

Solder Joints

- 1) Solder wires as shown, matching colors
- 2) Cover bare joints with heat shrink.

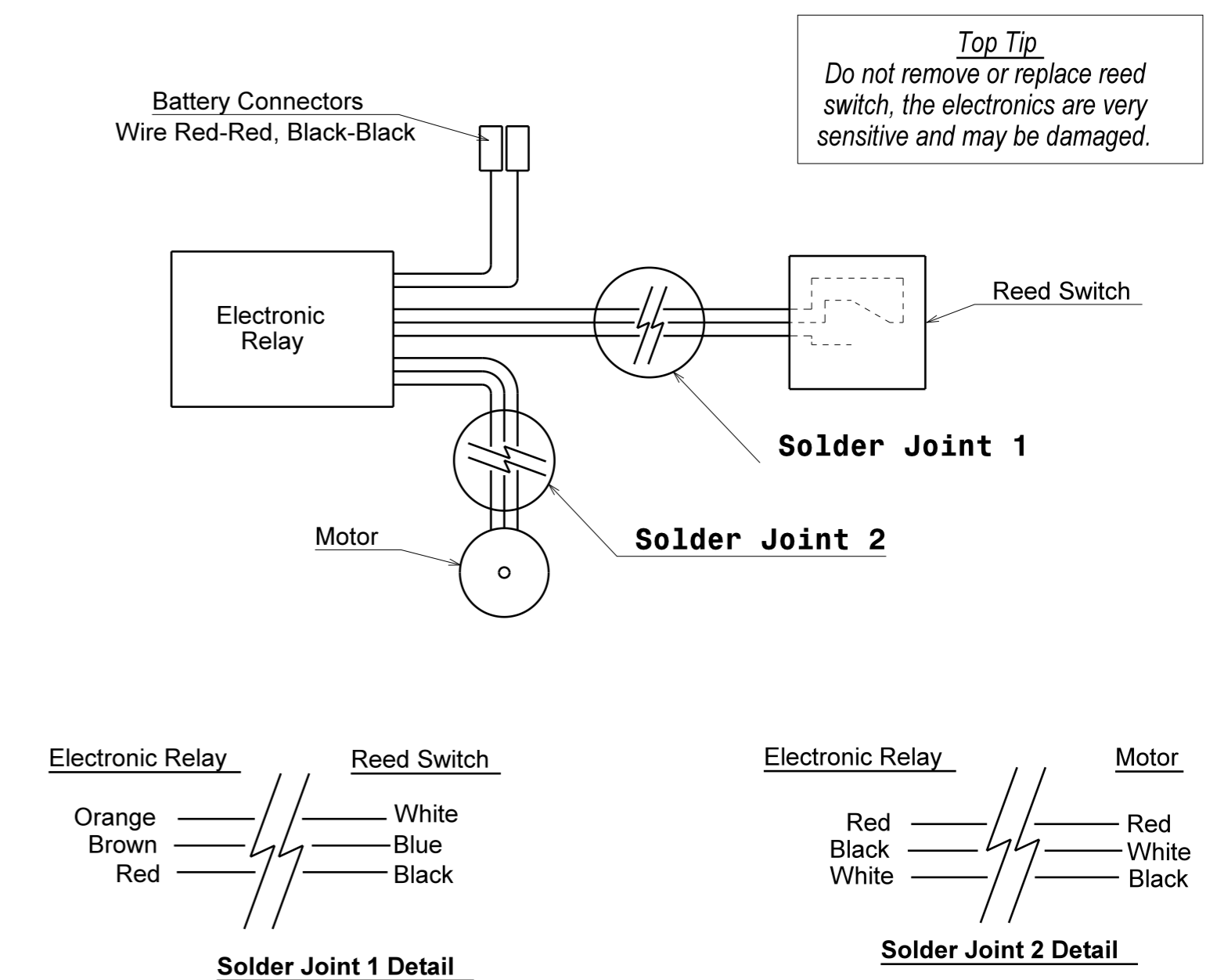

Body Assembly			
Item No.	Quantity	Dive Xtras Part No.	Description
1	1	M8x12-SHCS	M8 x 12 Metric Socket Head Cap Screw 316 Stainless steel
2	1	010-2001	Bracket, D-Ring, Body
3	1	000-0120-SST-2"	2" Stainless D-Ring
4	1	010-2101	Body Weldment, Stock, 13AH
5	4	HC-83314-LALB-SS	Catch
6	8	M3x6-SHCS	M3 x 6 Metric Socket Head Cap Screw, 316 Stainless Steel
7	1	2-365-O-RING	O Ring, 2-365, Nitrile
8	1	010-1011	Lower Retaining Ring, Battery

diveX © DIVE XTRAS 2004 ALL RIGHTS RESERVED
THIS DOCUMENT IS SUPPLIED IN CONFIDENCE. NO REPRODUCTION OF THE DOCUMENT OR ANY PART OF IT OR OF THE ITEMS SHOWN THEREON MAY BE MADE WITHOUT THE COPYRIGHT OWNERS WRITTEN PERMISSION.



All dimensions are in mm.
Deburr & Break all sharp edges

Engineer:
Ben McGeever

**Body Assembly Exploded
View & Electrical Diagram** Sheet

Drawing No:	Rev	1
xxx	1	1